

Mazak

QUICK TURN NEXUS 200/250, SUPER QUICK TURN 15/18, SUPER QUADREX 200/250

Data

Machine type Series	Turret Stations
QTNX 200/200-II M / MY / MS / MSY	12
QTNX 250/250-II M / MY / MS / MSY	12
SQ 200/250	12
SQT 15 M / MS	12
SQT 18 M / MS	12
SQT 200 M / MS	12
SQT 250 M / MS	12



Star-type Turret VDI 40

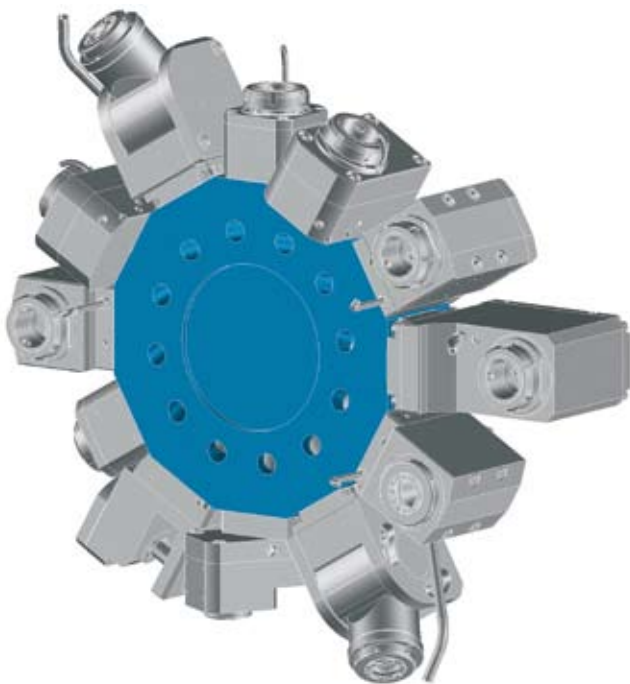

Interference Circles

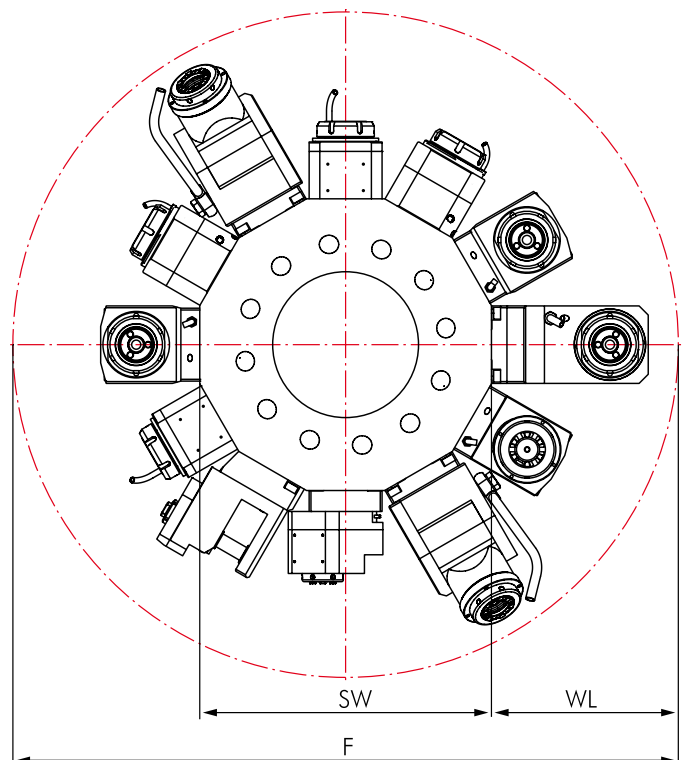

Machine type Series	F	SW	WL
QTNX 200/250	660	320	170
SQT 15/18	660	320	170
Super Quadrex 200/250	660	320	170

Mazak

QUICK TURN NEXUS 200/250, SUPER QUICK TURN 15/18, SUPER QUADREX 200/250

Driven Toolholders

	Page		Page
Straight Unit, Offset type	122		
		Angle Unit, adjustable 0-100°	125
			
Angle Unit	123		
		Y-Unit, adjustable ± 90°	126
			
Angle Unit, 2-Axis	124		
		Saw Blade Holder	127
			

Options and Accessories

mi Toolholders		mi System Description Toolholders Accessories	275 278-283 283-284
Static Toolholders for MAZAK		Static Toolholders Accessories	289-293 293-294
Accessories		Collets DIN 6499 Threading Collets Wrenches Clamping Nuts Sleeves and Bushings	309 309 309 309 310



Straight Unit, Offset and without Offset Type

for Manufacturer	
Mazak	
for Machine type	
NEXUS QTNX 200/250, SQT 15/18 + SUPER QUADREX 200/250	
QTNX	SQT
200 M/MS-12x	15 M/MS-12x
250 M/MS-12x	18 M/MS-12x
	200 M/MS-12x
	250 M/MS-12x
Dimensions	
Turret type	Star-type Turret
Shank	VDI 40
Drive	Tang
SW	10 mm

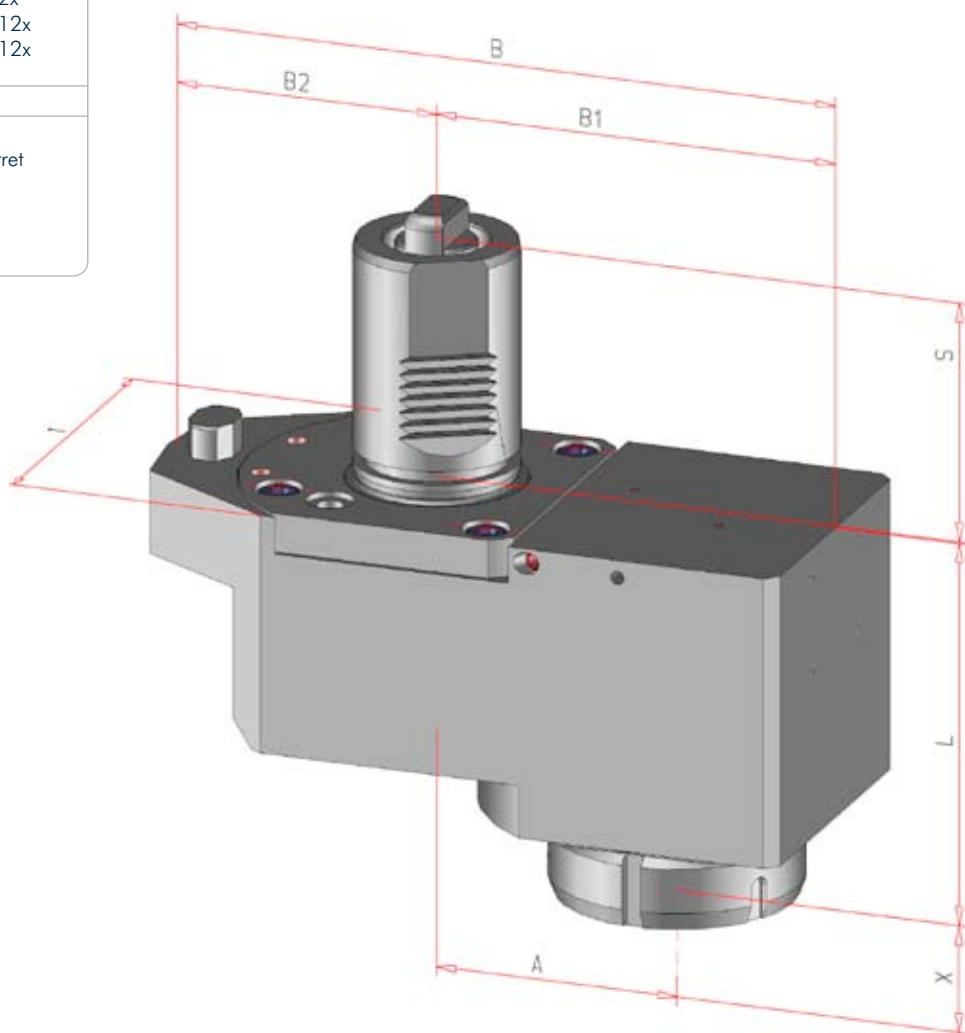

Order No.	Tool holder	Clamping range mm	Torque max.	n1/n2 (max.) (r.p.m.)	Gear Ratio	Coolant	X mm	L mm	A mm	B mm	B1 mm	B2 mm	S mm	T mm	MAZAK Ref. #
124034	ER 32	1,0-20	50 Nm	6.500 / 6.500	i = 1:1	external	80	90	50	170	90	80	70	80	532 080 20102
124259	ER 32	1,0-20	50 Nm	6.500 / 6.500	i = 1:1	internal	80	90	50	170	90	80	70	80	
123688	mi 50		50 Nm	6.500 / 6.500	i = 1:1	internal	80	90	50	170	90	80	70	80	
124067	ER 25	0,5-16	25 Nm	6.500 / 13.000	i = 1:2	external	98,5	71,5	50	164	84	80	70	68	
124375 *	ER 32	1,0-20	50 Nm	6.500 / 6.500	i = 1:1	external	80	90	50	132	90	42	70	80	
124025	mi 50		50 Nm	6.500 / 6.500	i = 1:1	external	80	90	50	170	90	80	70	80	
123711	mi 40			6.500 / 13.000	i = 1:2	internal	80	90	50	170	90	80	70	80	
124033	ER 25	0,5-16	50 Nm	6.500/6.500	i = 1:1	external	80	90	50	170	90	80	70	80	
Without offset:															
124256	ER 32	1,0-20	80 Nm	6.500/6.500	i = 1:1	internal	85	85	0				70	75	

Angle Unit

for Manufacturer	
Mazak	
for Machine type	
NEXUS QTNX 200/250, SQT 15/18 + SUPER QUADREX 200/250	
QTNX	SQT
200 M/MS-12x	15 M/MS-12x
250 M/MS-12x	18 M/MS-12x
	200 M/MS-12x
	250 M/MS-12x
Dimensions	
Turret type	Star-type Turret
Shank	VDI 40
Drive	Tang
SW	10 mm

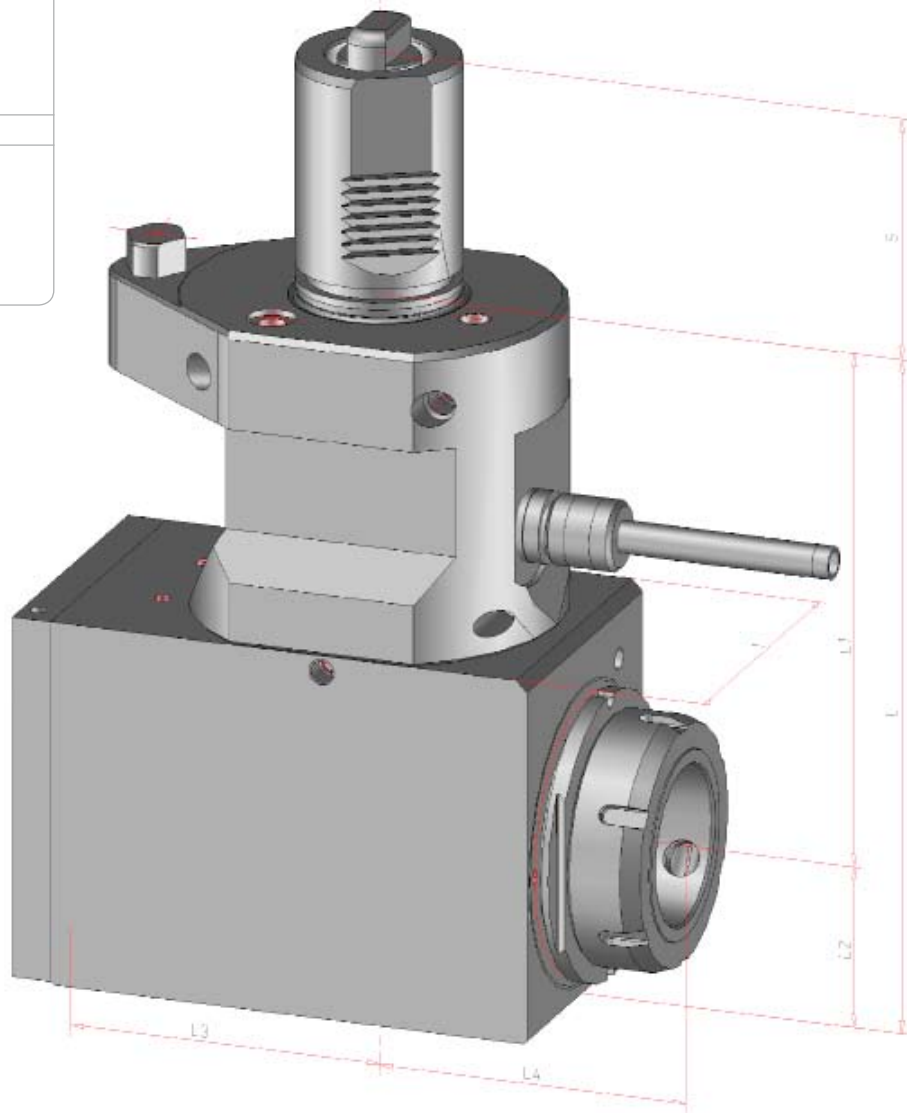

Order No.	Tool holder	Clamping range mm	Torque max.	n1/n2 (max.) (r.p.m.)	Gear Ratio	Coolant	L mm	L1 mm	L2 mm	L3 mm	L4 mm	S mm	T mm	MAZAK Ref. #
124635	ER 32	1,0-20	50 Nm	6.500 / 6.500	i = 1:1	external	169	130	39	69	70	70	80	532 080 20202
124691	ER 25	0,5-16	25 Nm	6.500 / 13.000	i = 1:2	external	164	130	34	40	78	70	80	
124873	ER 32	1,0-20	50 Nm	6.500 / 6.500	i = 1:1	internal	169	130	39	75,5	70	70	80	
124875	mi 50		50 Nm	6.500 / 6.500	i = 1:1	internal	173	130	43	71	83,5	70	80	
124636*	ER 32	1,0-20	50 Nm	6.500 / 6.500	i = 1:1	external	169	130	39	69	70	70	80	
124874*	ER 32	1,0-20	50 Nm	6.500 / 6.500	i = 1:1	internal	169	130	39	75,5	70	70	80	
101584	ER 25	0,5-16	25 Nm	6.500 / 13.000	i = 1:2	internal	169	130	39	72,5	75	70	80	
124639	mi 50		50 Nm	6.500 / 6.500	i = 1:1	external	173	130	43	71	83,5	70	80	
124919	mi 40		25 Nm	6.500 / 13.000	i = 1:2	internal	169	130	39	72,5	92	70	80	
167296	HF 20		50 Nm	6.500 / 6.500	i = 1:1	internal	169	130	39	75,5	82	70	80	

* Type for Back Sub-Spindle

Angle Unit, 2-Axis

for Manufacturer	
Mazak	
for Machine type	
NEXUS QTNX 200/250, SQT 15/18 + SUPER QUADREX 200/250	
QTNX	SQT
200 M/MS-12x	15 M/MS-12x
250 M/MS-12x	18 M/MS-12x
	200 M/MS-12x
	250 M/MS-12x
Dimensions	
Turret type	Star-type Turret
Shank	VDI 40
Drive	Tang
SW	10 mm

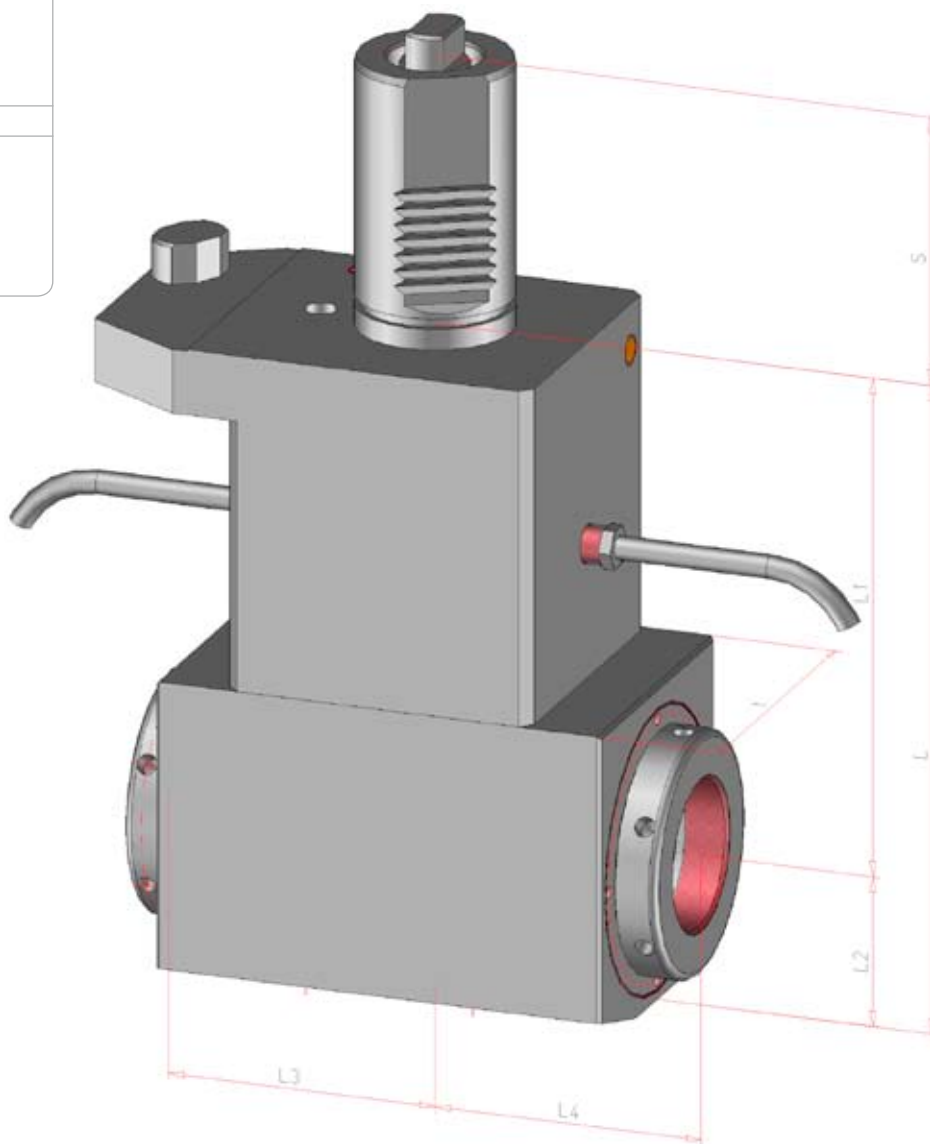

Order No.	Tool holder	Clamping range mm	Torque max.	n1/n2 (max.) (r.p.m.)	Gear Ratio	Coolant	L mm	L1 mm	L2 mm	L3 mm	L4 mm	S mm	T mm	MAZAK Ref. #
124632	2 x ER 25	0,5-16	25 Nm	6.500 / 6.500	i = 1:1	external	164	130	34	62	62	70	70	
124638	2 x ER 32	1,0-20	25 Nm	6.500 / 6.500	i = 1:1	external	169	130	39	70	70	70	80	
133725	2 x ER 32	1,0-20	25 Nm	6.500 / 6.500	i = 1:1	internal	169	130	39	70	93	70	80	

Angle Unit, adjustable 0-100°

for Manufacturer

Mazak

for Machine type

**NEXUS QTNX 200/250, SQT 15/18
+ SUPER QUADREX 200/250**

QTNX

200 M/MS-12x
250 M/MS-12x

SQT

15 M/MS-12x
18 M/MS-12x
200 M/MS-12x
250 M/MS-12x

Dimensions

Turret type	Star-type Turret
Shank	VDI 40
Drive	Tang
SW	10 mm

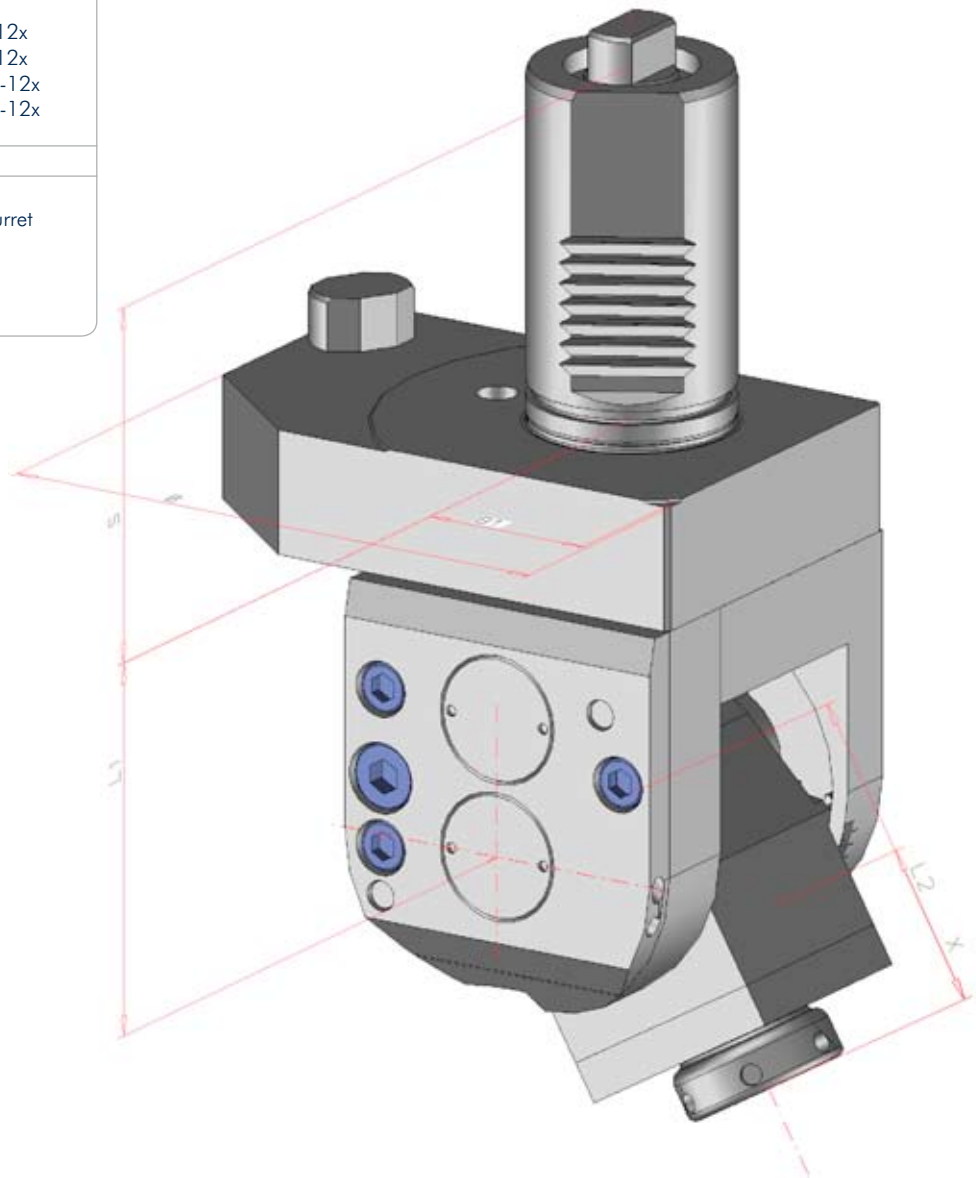

Order No.	Tool holder	Clamping range mm	Torque max.	n1/n2 (max.) (r.p.m.)	Gear Ratio	Coolant	X mm	L mm	L1 mm	L2 mm	B mm	S mm	T mm	MAZAK Ref. #
125027	ER 16	0,5-10	6 Nm	6.500 / 6.500	i = 1:1	external	35,5	134,5	73,5	61	114	70	80,5	
125054	ER 16	0,5-10	6 Nm	3.750 / 15.000	i = 1:4	external	35,5	134,5	73,5	61	114	70	80,5	

Y-Unit, adjustable $\pm 90^\circ$

for Manufacturer

Mazak

for Machine type

**NEXUS QTNX 200/250, SQT 15/18
+ SUPER QUADREX 200/250**

QTNX

200 M/MS-12x
250 M/MS-12x

SQT

15 M/MS-12x
18 M/MS-12x
200 M/MS-12x
250 M/MS-12x

Dimensions

Turret type	Star-type Turret
Type	$\pm 90^\circ$ continuous adjustable
Shank	VDI 40
Drive	Tang
SW	10 mm

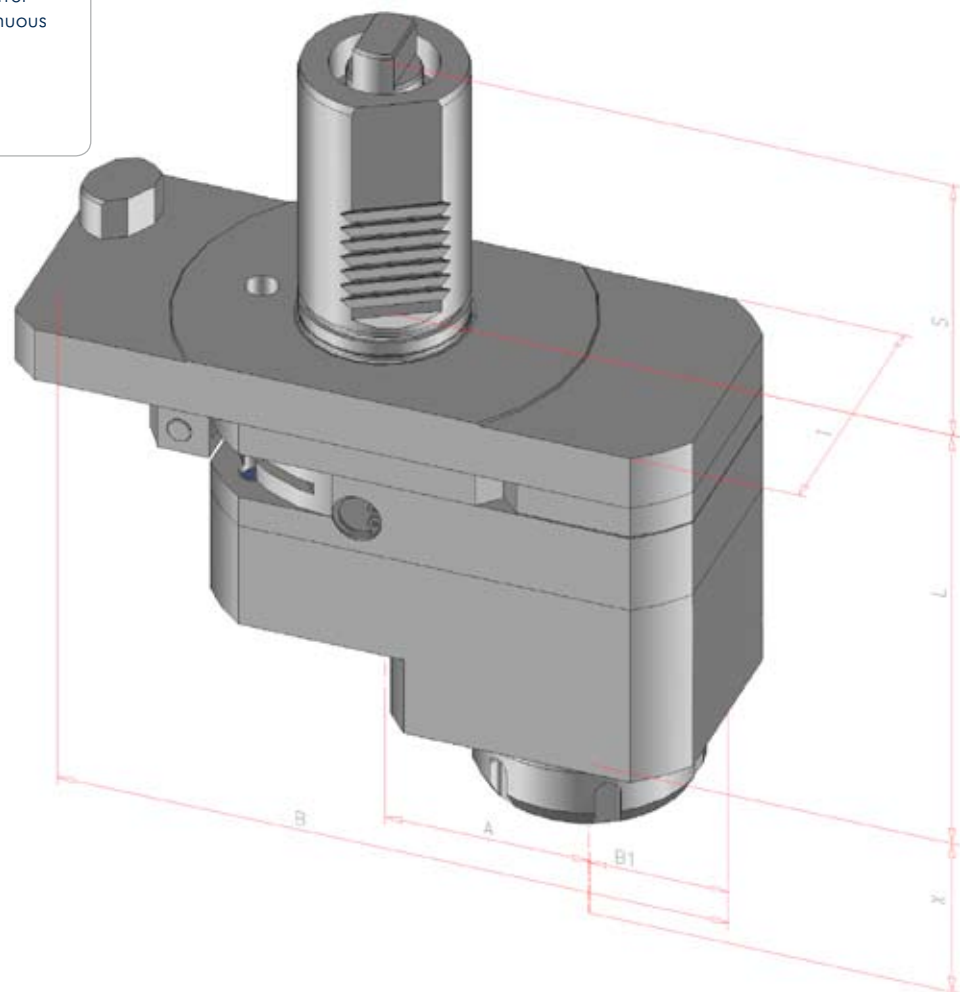

Order No.	Tool holder	Clamping range mm	Torque max.	n1/n2 (max.) (r.p.m.)	Gear Ratio	Coolant	X mm	L mm	A mm	B mm	S mm	T mm	MAZAK Ref. #
124118	ER 25	0,5-16	25 Nm	6.500 / 6.500	i = 1:1	external	70	100	50	164	70	68	

Saw Blade Holder

for Manufacturer

Mazak

for Machine type

**NEXUS QTNX 200/250, SQT 15/18
+ SUPER QUADREX 200/250**

QTNX

200 M/MS-12x
250 M/MS-12x

SQT

15 M/MS-12x
18 M/MS-12x
200 M/MS-12x
250 M/MS-12x

Dimensions

Turret type	Star-type Turret
Shank	VDI 40
Drive	Tang
SW	10 mm

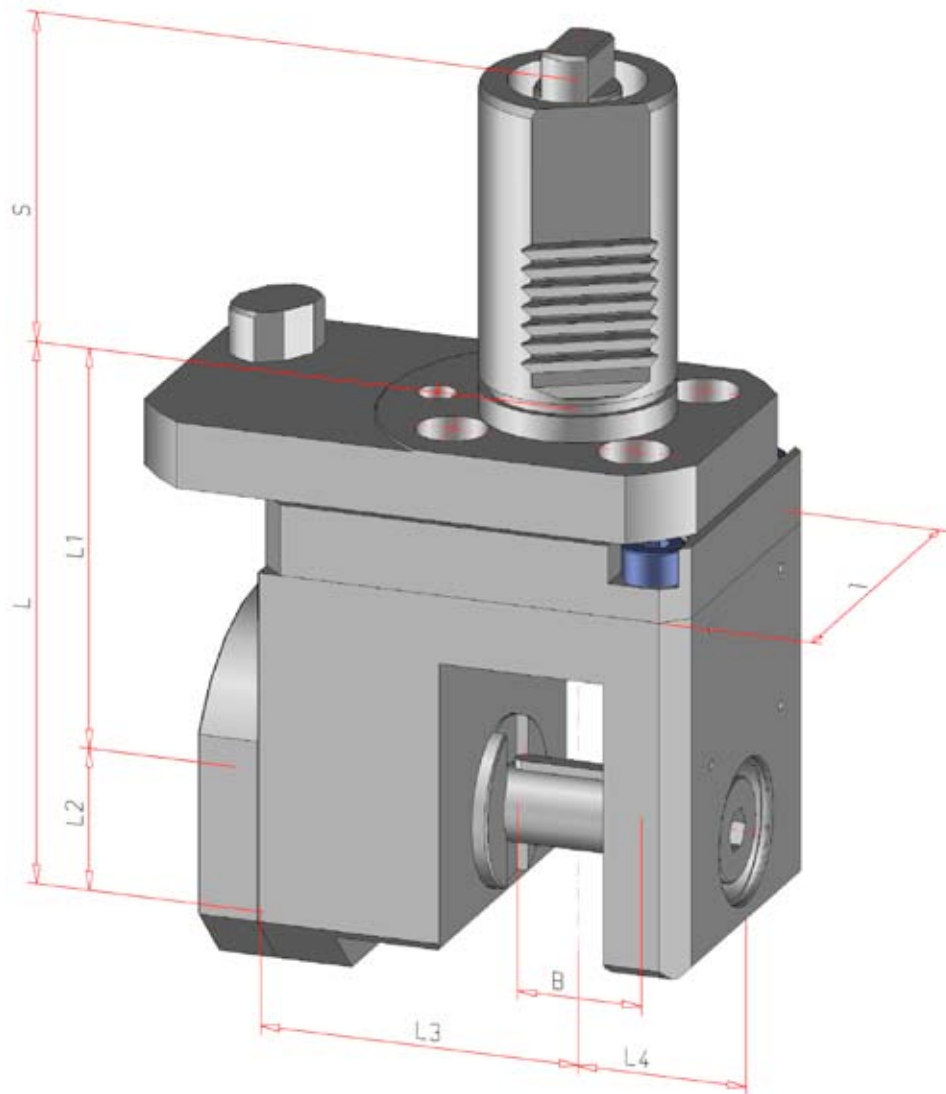

Order No.	Fitting dia. mm	Torque max.	n1/n2 (max.) (r.p.m.)	Gear Ratio	Coolant	L mm	L1 mm	L2 mm	L3 mm	L4 mm	B mm	S mm	T mm	MAZAK Ref. #
125104	22	20 Nm	6.500 / 2.450	i = 2,66:1	external	115	85	30	77,5	36	25	70	72	
125123	22	40 Nm	6.500 / 2.450	i = 2,66:1	external	165	130	35	87,5	36	25	70	72	