

**Data**

Machin type series	Turret Stations
<b>B 301 / 545</b> M / SM / Y / YS	12
<b>B 550 / 565</b> M / SM / Y / YS	12
<b>B 501</b> M / SM	12

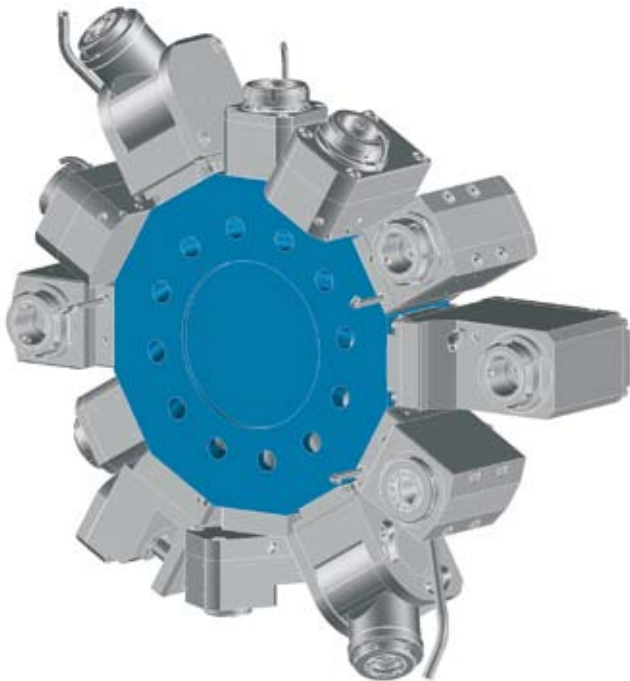

**Star-type Turret „BMT“**



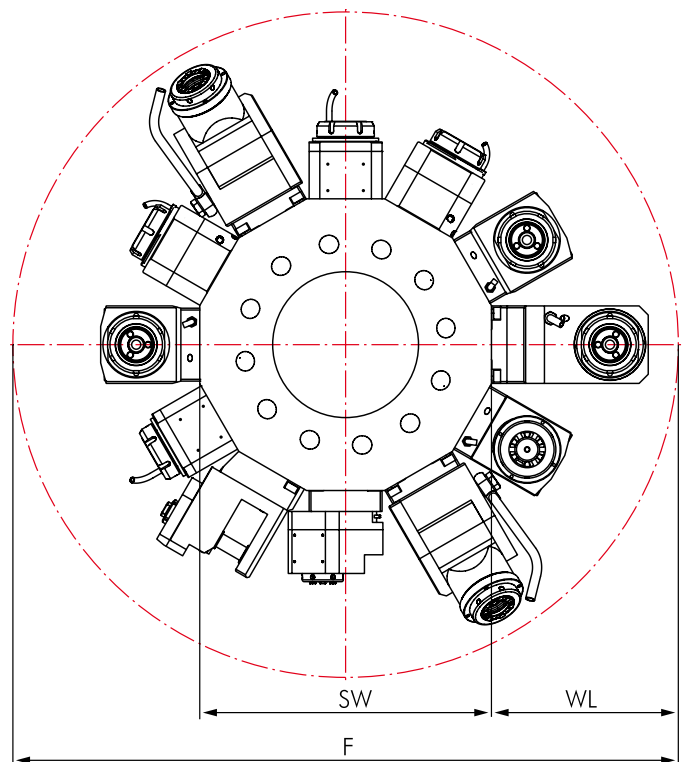

**Interference Circles**



Machine type Series	F	SW	WL
<b>B301 / B545</b>	575	320	127,5
<b>B445 / B470</b>	565	320	122,5
<b>B501 / B565</b>	600	320	140,0

## Driven Toolholders

	Page		Page
<b>Straight Unit</b>			
	260		
<b>Angle Unit</b>			
			261

## Options and Accessories

<b>Accessories</b>		
		
	Collets DIN 6499	309
	Threading Collets	309
	Wrenches	309
	Clamping Nuts	309
	Sleeves and Bushings	310



## Straight Unit

for Manufacturer	
 <p><b>Biglia</b> The turning tech</p>	
for Machine type	
<p><b>B 301 / 545</b> <b>B 550 / 565</b> <b>B 501</b></p>	
Dimensions	
Turret type	Star-type Turret
Shank	BMT Ø 55 mm
Drive	Tang
SW	8 mm

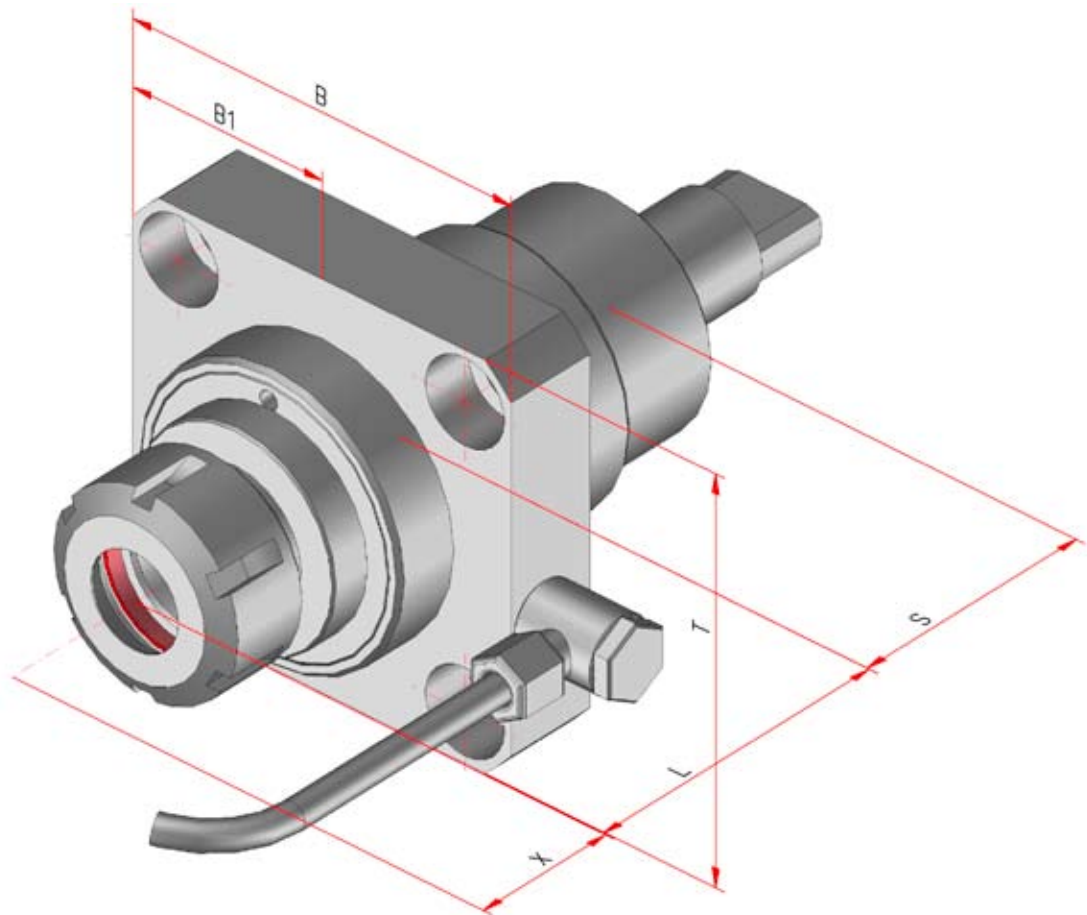

Order No.	Tool holder	Clamping range mm	Torque max.	n1/n2 (max.) (r.p.m.)	Gear Ratio	Coolant	X mm	L mm	B mm	B1 mm	S mm	T mm
123775	ER 25	0,5-16	50 Nm	6.500 / 6.500	i = 1:1	external	70	70	84	42	79	42

# Angle Unit

for Manufacturer



for Machine type

**B 301 / 545**  
**B 550 / 565**  
**B 501**

Dimensions

Turret type	Star-type Turret
Shank	BMT Ø 55 mm
Drive	Tang
SW	8 mm

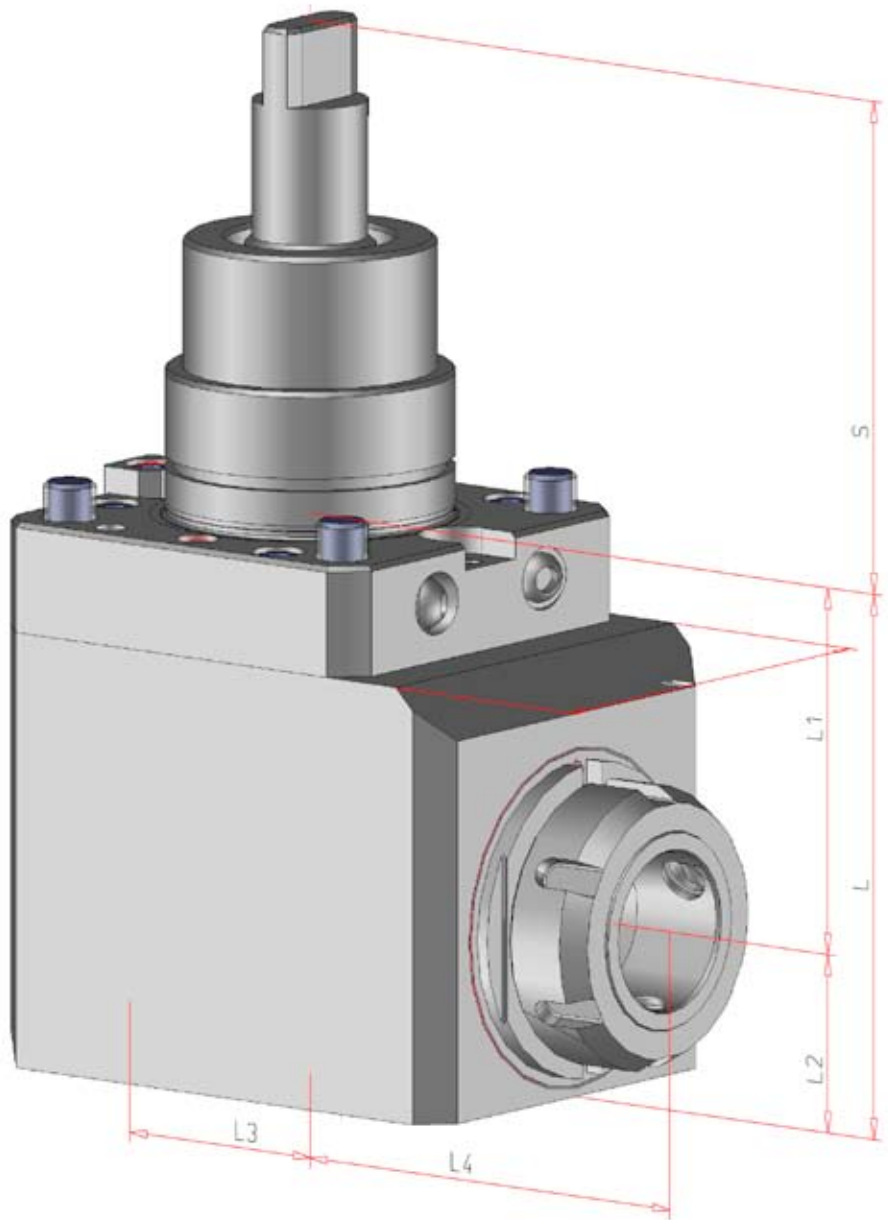

Order No.	Tool holder	Clamping range mm	Torque max.	n1/n2 (max.) (r.p.m.)	Gear Ratio	Coolant	L mm	L1 mm	L2 mm	L3 mm	L4 mm	S mm	T mm
124489	ER 25	0,5-16	25 Nm	6.500 / 6.500	i = 1:1	external	104	70	34	43	72	79	84